

Technical Data



**KR 30 HA – KR 60 HA –
KR 60 L45 HA – KR 60 L30 HA**



KUKA

WORKING IDEAS

KR 30 HA, KR 60 HA, KR 60 L45 HA, KR 60 L30 HA

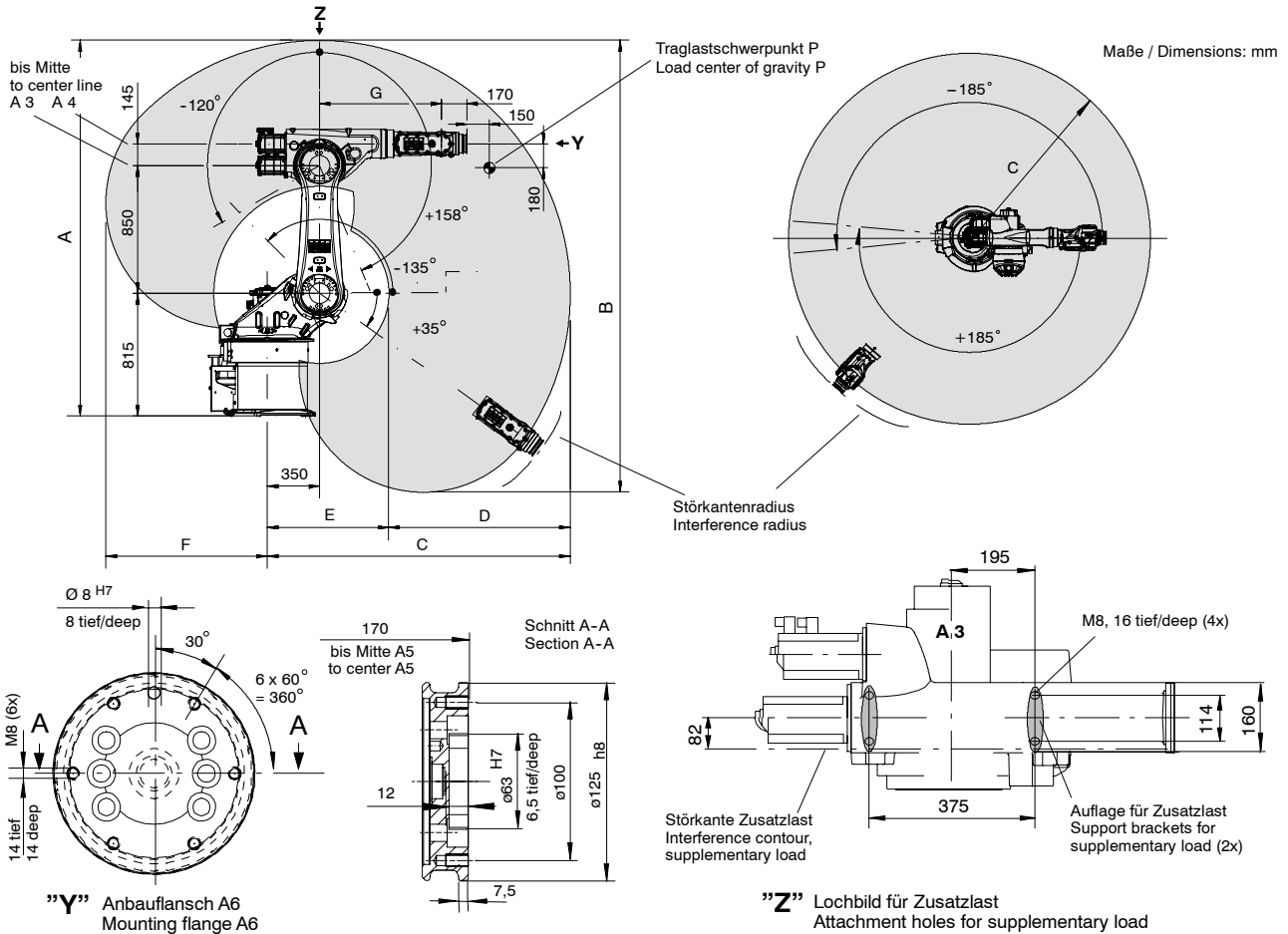

Typ / Type:	KR 30 HA	KR 60 HA	KR 60 L45 HA	KR 60 L30 HA				
Traglast / Payload:	30 kg	60 kg	45 kg	30 kg				
Zusatzlast / Supplementary load:	35 kg	35 kg	35 kg	35 kg				
Max. Gesamtlast / Total distributed load:	65 kg	95 kg	80 kg	65 kg				
Armlänge / Arm length:	820 mm	820 mm	1020 mm	1220 mm				
Anzahl der Achsen / Number of axes:	6							
Handvariante / Wrist variant:	Zentralhand / In-line wrist							
Anbauflansch A 6 / Mounting flange A 6:	DIN ISO 9409-1-A100							
Einbaulage / Mounting position:	Boden, Decke / Floor, ceiling							
Wiederholgenauigkeit (ISO 9283) / Repeatability (ISO 9283):	± 0,10 mm	± 0,15 mm	± 0,20 mm	± 0,20 mm				
Steuerung / Controller:	KR C2							
Gewicht (ohne Steuerung) ca. / Weight (excl. controller) approx.:	665 kg	665 kg	671 kg	679 kg				
Achsdaten / Axis data:	Bereich (Software) Range (software)		Geschwindigkeit / Speed					
Achse / Axis 1 (A1)	± 185°		140°/s					
Achse / Axis 2 (A2)	+35°/-135°		126°/s					
Achse / Axis 3 (A3)	+158°/-120°		140°/s					
Achse / Axis 4 (A4)	±350°		260°/s					
Achse / Axis 5 (A5)	±119°		245°/s					
Achse / Axis 6 (A6)	±350°		322°/s					
Arbeitsraum / Work envelope:	Maße / Dimensions ¹⁾							Volumen Volume
	A	B	C	D	E	F	G	
KR 30 HA	2498	3003	2033	1218	815	1084	820	27,2 m ³
KR 60 HA	2498	3003	2033	1218	815	1084	820	27,2 m ³
KR 60 L45 HA	2695	3398	2230	1362	868	1283	1020	36,9 m ³
KR 60 L30 HA	2894	3795	2429	1445	983	1480	1220	47,8 m ³

1) Bezogen auf Schnittpunkt Achse 4/5. / Referred to intersection of axes 4 and 5

- Antriebssystem elektro-mech. mit bürstenlosen AC-Servomotoren. / Drive system electromechanical, with brushless AC servomotors.
- Wegmesssystem digital-absolut. / Position sensing system digital-absolute.

Angaben über die Beschaffenheit und Verwendbarkeit der Produkte stellen keine Zusicherungen von Eigenschaften dar, sondern dienen lediglich Informationszwecken. Maßgeblich für den Umfang unserer Lieferungen und Leistungen ist der jeweilige Vertragsgegenstand. Technische Daten und Abbildungen unverbindlich für Lieferung. Änderungen vorbehalten.
Specifications regarding the quality and usability of the products do not constitute a warranty of properties. They are intended to serve informative purposes only. Solely the respective contract of sale shall be binding in respect of the extent of our supplies and services. No liability accepted for errors or omissions.

www.kuka.com