

Casting Solutions_Trim Press SEP 13-07-50 ECO

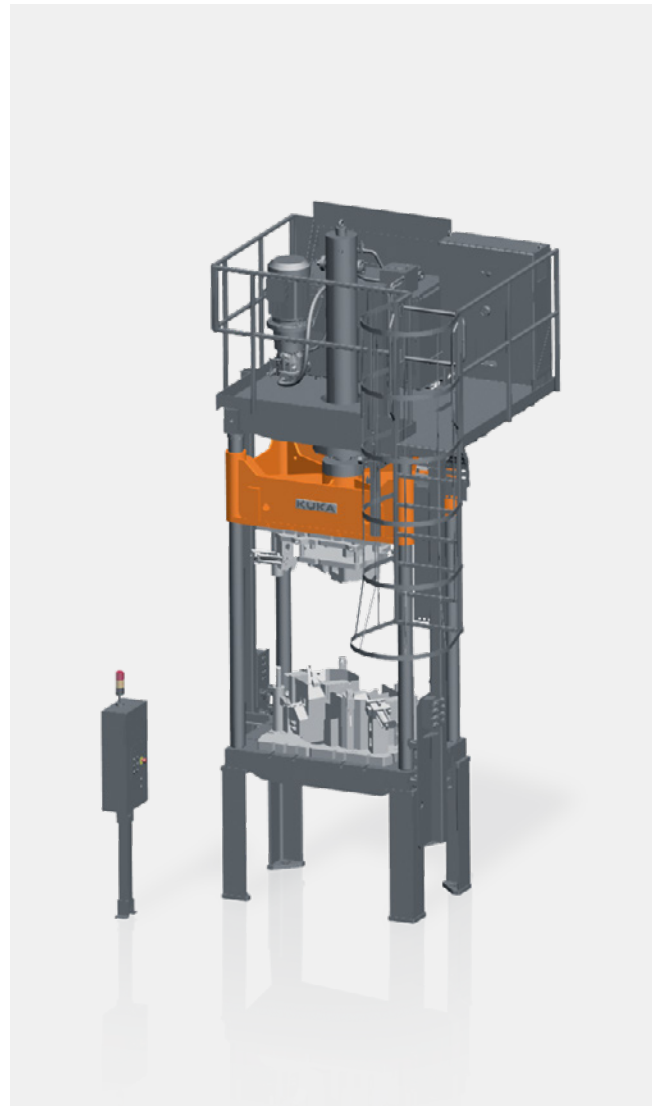
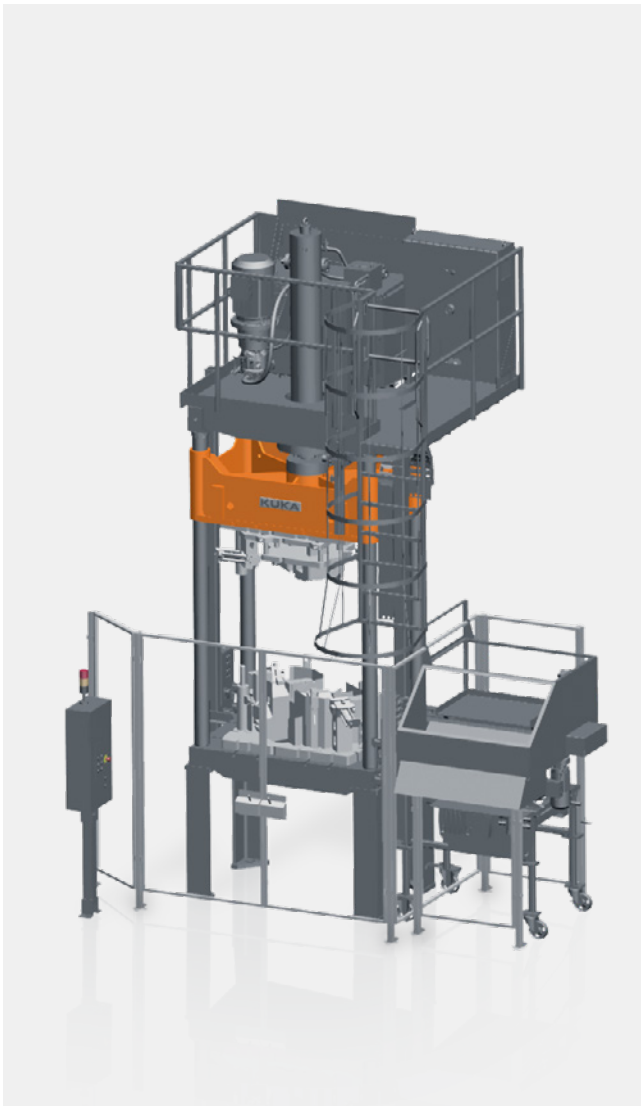

The perfect press for automated die casting

Why the SEP13-07-50 Eco trim press?

Increasing cost pressure requires machine suppliers to come up with new, innovative concepts for facilitating the manufacture of cost-effective production machines.

The SEP13-07-50 Eco trim press is specially tailored for integration into automated die-casting cells. The installation height and stroke are optimally designed for automatic deburring. Flexible integration of the trimming tools is achieved through two side loader connections at the front and two side loader connections at the rear as standard. The table height is chosen extra high to allow large containers to be used for long change cycles.

Casting Solutions_Trim Press SEP 13-07-50 ECO

Technical data

	Unit	SEP 13-07-50 ECO
Press force (cylinder)	kN	500
Retraction force without tool (cylinder)	kN	50
Min. clearance between columns	mm	1,300 x 700
Installation height	mm	1,800
Stroke	mm	1,200
Velocities	mm/s	135
	mm/s	65
	mm/s	125
Velocities for plunger with upper tooling weight	kg	2,000
Connected load	kVA	15
Weight, approx.	T	11
Tank capacity	l	450
Max. system pressure	bar	200
Platform		yes

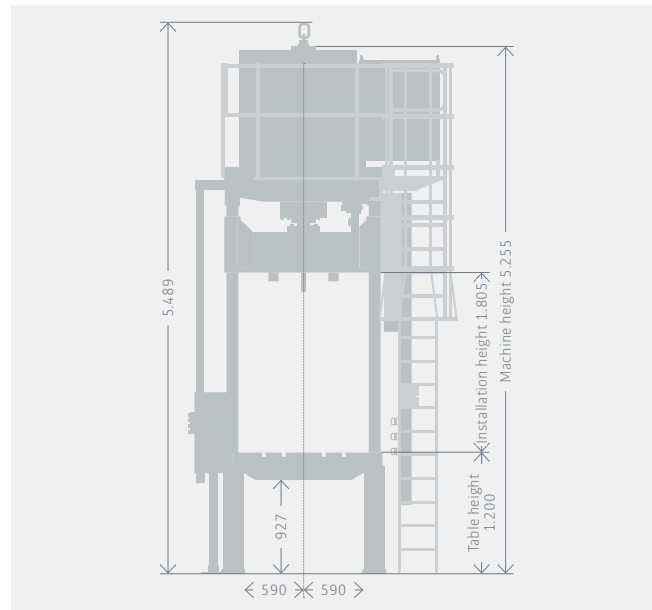

SEP 13-07-50 ECO

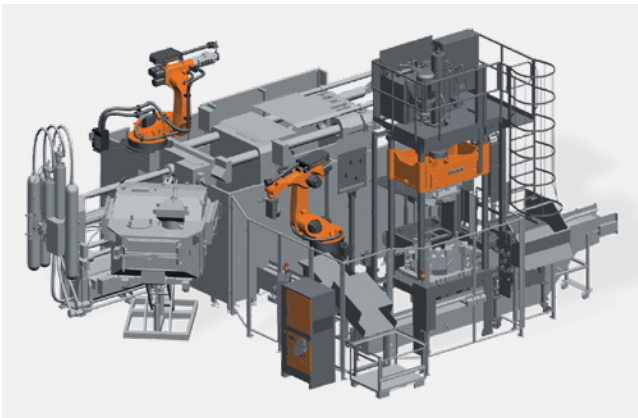

Fully integrated into the protected area of the system

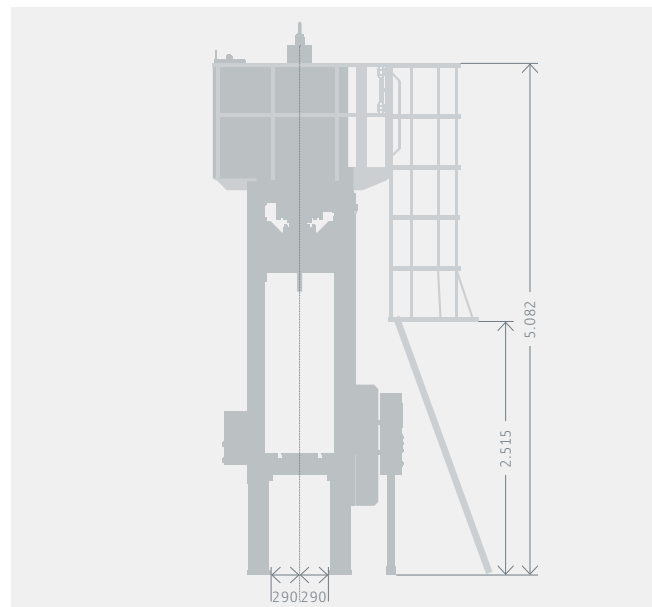

For further information please contact us at
casting.industries.de@kuka.com