

# KUKA



Medical Robotics\_LBR Med



**KUKA, a proven robotics partner.** Discerning users around the world value KUKA as a reliable partner. KUKA has branches in over 30 countries, and for over 40 years, we have been making our mark as a pioneer and trailblazer with sophisticated robotics. Medical experts have valued the advantage of our experience over the past 15 years. At KUKA, you will find technologies that are custom-tailored to your requirements. As your partner, we are on hand to support you throughout the entire product life cycle.



# KUKA

Your partner in the field of medical robotics

For decades, KUKA robots have been used for research, development and production. They are service-proven, reliable high-tech systems for exceptional precision, continuity and quality. By choosing KUKA, you are opting for pioneering technologies and the reliability of longstanding customer relationships. Gain valuable planning security for your medical technology company and benefit from our expertise in challenging medical applications.

## LBR Med

Unique technology specially for your field of application

The LBR Med bundles all robot capabilities that are particularly required in medical technology. **KUKA supplies the LBR Med as a robotic component for integration into a medical product.** This integration is surprisingly easy, as KUKA provides you with a CB Report in accordance with IEC 60601-1 and IEC 62304 for the LBR Med in cooperation with VDE.



**Precise.** The LBR Med requires no additional devices for calibration or highly precise work. Thanks to its integrated mastering sensors, it calibrates itself fully autonomously and achieves an outstanding repeatability from  $\pm 0.1$  mm to  $\pm 0.15$  mm.



**Flexible.** The LBR Med is designed as a robot that can be deployed universally. It can be integrated seamlessly into a wide range of different applications. The required interfaces come as standard in large numbers, as the robot is based on the LBR iiwa that has proven its worth

in Industrie 4.0 settings. The LBR Med is easy to integrate into applications using the most commonly-used programming language JAVA and the readily comprehensible KUKA robot library. It can thus be used "out of the box" for product development in medical technology.

## LBR Med

Multitool for different applications



**Orthopedic surgery:** Thanks to its stable design and construction, as well as its high stiffness, the LBR Med is suitable for bone surgery. Open-source libraries facilitate the fast development of prototypes and the integration of navigation cameras.



**Ultrasound diagnostics:** Sensitive technology and safe human-robot collaboration are the domain of the LBR Med. Thanks to the integrated sensors, it can react to its surroundings both interactively with the physician and via telemanipulation.



**Minimally invasive surgery:** The highly developed controller enables precise operation with a trocar kinematic system. The user can freely select whether to use the application automatically, interactively or via a telemanipulator.



**Safe.** The LBR Med sets standards with its safety structures. Its safety-rated hardware and software processes the relevant data. Functions covered by the equipment include encoder signals, force/torque sensors, safety circuit, single fault safety, safety-rated interfaces and configurable safety events – in short: everything that predestines it for medical technology.



**Sensitive.** The LBR Med has redundant, integrated torque sensors. It can detect forces applied externally and react according to the freely programmable system responses you have specified. Benefit from its haptic capabilities for manual guidance, teleoperation with haptic support or gravity compensation. Use the LBR Med to apply predefined forces during a motion or as a compliant robot that responds adaptively to process forces. Furthermore, the integrated sensors are also used for safe collision detection, thereby enabling human-robot collaboration (HRC).

# Technical data

## Scope of supply

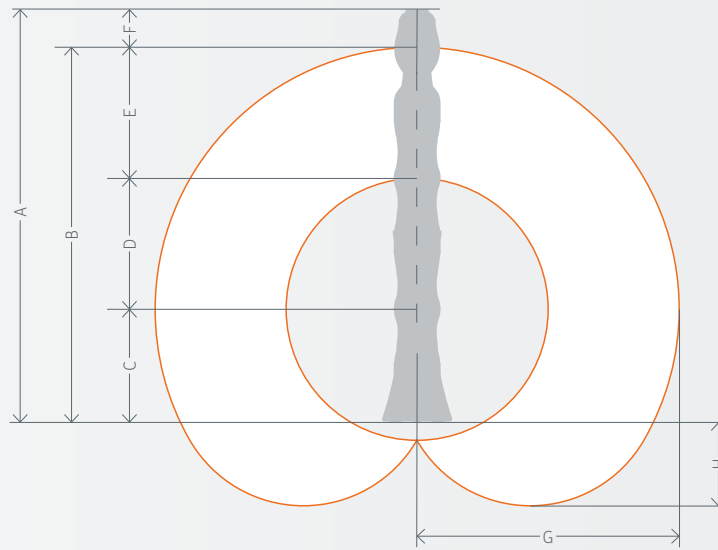

LBR Med	LBR Med 7 R800	LBR Med 14 R820	Workspace	LBR Med 7 R800	LBR Med 14 R820
Max. total payload	7 kg	14 kg	Dimensions A	1,266 mm	1,306 mm
Number of axes	7	7	Dimensions B	1,140 mm	1,180 mm
Wrist variant	In-line wrist	In-line wrist	Dimensions C	340 mm	360 mm
Mounting flange A7	DIN ISO 9409-1-A50	DIN ISO 9409-1-A50	Dimensions D	400 mm	420 mm
Installation position	any	any	Dimensions E	400 mm	400 mm
Positioning accuracy (ISO 9283)	±0.1 mm	±0.15 mm	Dimensions F	126 mm	126 mm
Axis-specific speed accuracy (at max. speed)	±2 %	±2 %	Dimensions G	800 mm	820 mm
Weight	25.5 kg	32.3 kg	Dimensions H	260 mm	255 mm
Protection rating	IP54	IP54	Volume	1.7 m <sup>3</sup>	1.8 m <sup>3</sup>



**Media flange inside electrical Med:** Connections for power supply, I/Os or EtherNet are available for customer-specific tools on the flange via the media flange inside electrical Med.



**Controlling the future: KUKA Sunrise.** The basis for the innovative LBR robotics consists of the specially developed KUKA Sunrise control technology, the KUKA Sunrise Cabinet Med control hardware and the KUKA Sunrise.OS control software.

KUKA Sunrise Cabinet Med unites safety control, robot control, logic control and process control of the entire system. Its interfaces, scalability, performance and openness mean that there are virtually limitless automation possibilities. In the future, it will also be possible to control multiple lightweight robots with a single controller.



[www.kuka.com/contacts](http://www.kuka.com/contacts)



[www.facebook.com/KUKA.Robotics](https://www.facebook.com/KUKA.Robotics)



[www.youtube.com/kukarobotgroup](https://www.youtube.com/kukarobotgroup)



Twitter: @kuka\_roboticsEN

Details provided about the properties and usability of the products are purely for information purposes and do not constitute a guarantee of these characteristics. The extent of goods delivered is determined by the subject matter of the specific contract. No liability accepted for errors or omissions. Subject to technical alterations.

© 2017 KUKA