



KR 6 R700 sixx



Technical data

Maximum reach	706.7 mm
Maximum payload	6 kg
Pose repeatability (ISO 9283)	± 0.03 mm
Number of axes	6
Mounting position	Floor
Footprint	320 mm x 320 mm
Weight	approx. 50 kg

Axis data

Motion range	
A1	±170 °
A2	-190 ° / 45 °
A3	-120 ° / 156 °
A4	±185 °
A5	±120 °
A6	±350 °

Operating conditions

Ambient temperature during operation	5 °C to 45 °C (278 K to 318 K)
--------------------------------------	--------------------------------

Protection rating

Protection rating (IEC 60529)	IP54
Protection rating, robot wrist (IEC 60529)	IP54

Controller

Controller	KR C4 smallsize-2; KR C4 compact
------------	-------------------------------------

Cycle time

138 cycles per minute (25 mm / 305 mm / 25 mm, 1 kg)

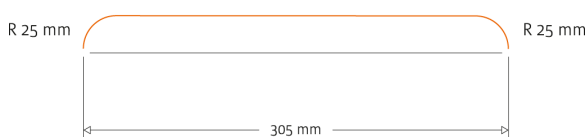

Workspace graphic

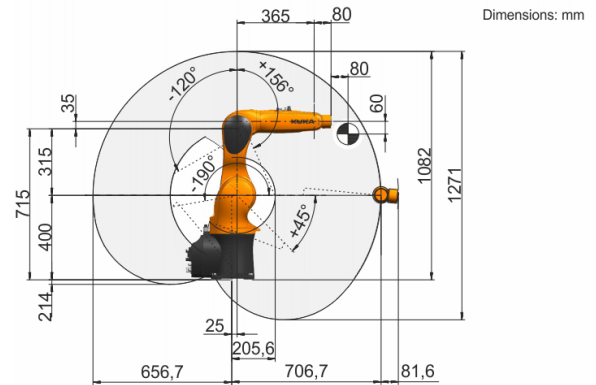

Payload diagram

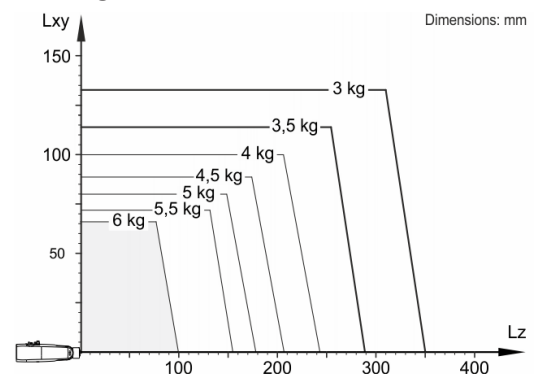

The KR 6 R700 sixx is designed for a rated payload of 3 kg in order to optimize the dynamic performance of the robot. With reduced load center distances and favorable supplementary loads, a maximum payload of up to 6 kg can be mounted. The specific KUKA Load case must be verified using KUKA. For further consultation, please contact KUKA Service.

Mounting flange

