

KUKA

**The Series 2000
shelf-mounted robots for
shorter cycle times**



**Series 2000
KR 150-2 K**



product
design
award

2002 ■



reddot design award
winner 2002



reddot
best of the best

»THE SERIES 2000 SHELF-MOUNTED ROBOTS: THE MODULAR SPACE-SAVERS

The Series 2000 shelf-mounted robots stand for greater flexibility and a longer downward reach: with powerful motors, high-performance gear units and amplified servo drive, they achieve high output with payloads of up to 210 kg and a work envelope of up to 8 m in diameter. With installation on either the floor or a machine, the series is versatile, space-saving and ideally suited to challenging removal processes.

Thanks to their modular design, three arm length variants and large product portfolio, the Series 2000 shelf-mounted robots can be quickly upgraded or converted. For cleanrooms or environments with a high degree of fouling and high temperatures, the special variants Cleanroom (CR) and Foundry (F) are available. **The advantages: a high degree of planning reliability and security of investment.**

»EXTREMELY MODULAR – EXTREMELY EXPANDABLE

The Series 2000 shelf-mounted robots are available in three arm length variants and have a large product portfolio with a total of 31 variants. Thanks to their modular design, the robots can also be quickly retrofitted for increased payload or reach. There's no more laborious, cost-intensive implementation of new systems – and production can start in record time. **The advantages: flexible production and rapid commissioning.**

»EXTREMELY POWERFUL – EXTREMELY PRECISE

High speed and maximum output: the high installed motor capacity and high-torque gear units in all axes make the Series 2000 shelf-mounted robots highly dynamic and extremely powerful. Added to this is the precision control, which gives these high-performers a repeatability of ± 0.06 mm. The result: better manufacturing quality, fewer rejects, and thus greater efficiency for your production. **The advantages: shorter cycle times and higher quality.**

»TECHNICAL DETAILS KR 150-2 K

Dimensions: mm

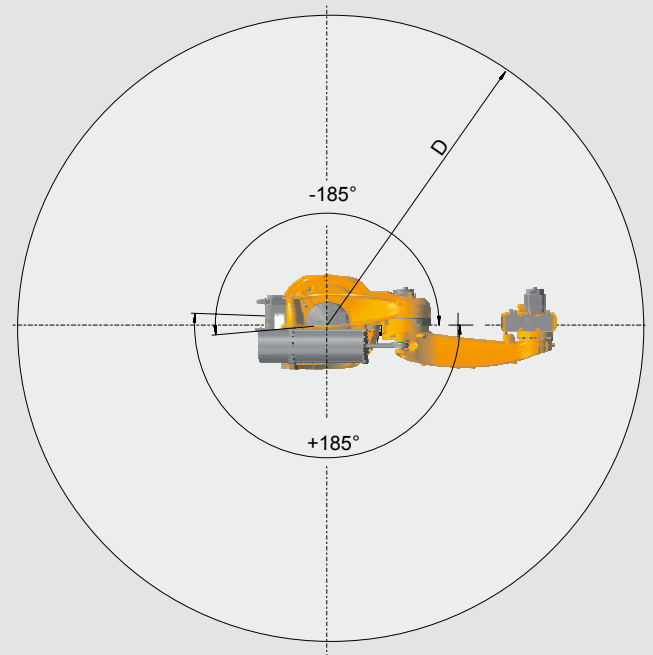
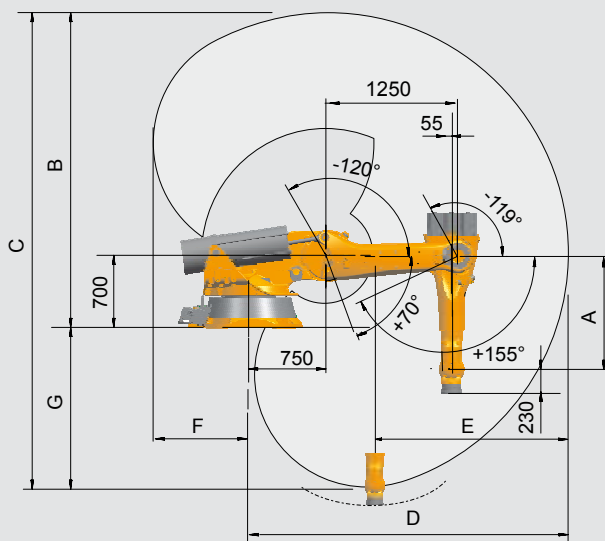

Work envelope	Dimensions ¹⁾							Volume
	A	B	C	D	E	F	G	
KR 150-2 K	1,100 mm	3,050 mm	4,625 mm	3,100 mm	1,876 mm	976 mm	1,575 mm	97.0 m ³
KR 150 L130-2 K	1,300 mm	3,250 mm	5,025 mm	3,300 mm	2,048 mm	1,176 mm	1,775 mm	120.0 m ³
KR 150 L110-2 K	1,500 mm	3,450 mm	5,425 mm	3,500 mm	2,151 mm	1,376 mm	1,975 mm	145.0 m ³

¹⁾ Relative to intersection of axes 4/5

»EXTREMELY WELL-DESIGNED – EXTREMELY ERGONOMIC

Designed for maximum cost-effectiveness: with a low robot base and axis 2 located 400 mm further forward, the shelf-mounted robots are perfect for working from above, for example for efficient removal of castings or plastic parts. Thanks to their low weight, they can also be installed directly on the machine, thereby saving space and enabling them to reach far into the machine with great speed. **The advantages: reduced space requirements and improved process optimization.**



KUKA shelf-mounted robots are ideal for unloading parts from injection molding machines.

»EXTREMELY VERSATILE – EXTREMELY SAFE

KUKA offers you a comprehensive range of software. In addition to expandable system software and simulation programs for system design, we also provide you with specific application software, such as KUKA.PlastTech: the software coordinates and optimizes the work process of robots and injection molding machines – thereby reducing the cycle time for production of the parts. **The advantages: maximum ease of operation and major time savings.**



The low base is specially optimized for working downwards.

Type	KR 150-2 K	KR 150 L130-2 K	KR 150 L110-2 K
Maximum reach	3,100 mm	3,300 mm	3,500 mm
Rated payload	150 kg	130 kg	110 kg
Suppl. load, arm/link arm/rotating col.	50/100/300 kg		
Suppl. load, arm + link arm, max.	100 kg		
Maximum total load	550 kg	530 kg	510 kg
Number of axes	6		
Mounting position	Shelf-mounted, floor		
Variant	Cleanroom, Foundry		
Positioning repeatability*	±0.06 mm		
Path repeatability*			
Controller	KR C2 edition2005		
Weight (excluding controller), approx.	1,445 kg	1,455 kg	1,465 kg
Temperature during operation	+10 °C to +55 °C		
Protection classification	IP 65		
Robot footprint	1,006 mm x 1,006 mm		
Connection	7.3 kVA		
Noise level	< 75 dB		

The Series 2000 shelf-mounted robots comprise the KR 150-2 K, KR 180-2 K and KR 210-2 K.

Drive system, electromechanical with brushless AC servomotors

*to ISO 9283

Axis data	Range (software)	Speed with rated payload		
		150 kg	130 kg	110 kg
Axis 1 (A1)	±185°	96°/s	95°/s	93°/s
Axis 2 (A2)	+70°/-120°	96°/s	87°/s	86°/s
Axis 3 (A3)	+155°/-119°	95°/s	90°/s	86°/s
Axis 4 (A4)	±350°	171°/s	171°/s	171°/s
Axis 5 (A5)	±125°	171°/s	171°/s	171°/s
Axis 6 (A6)	±350°	238°/s	238°/s	238°/s

Details provided about the properties and usability of the products are purely for information purposes and do not constitute a guarantee of these characteristics. The extent of goods delivered and services performed is determined by the subject matter of the specific contract. No liability accepted for errors or omissions.



»THE KUKA ROBOT GROUP: YOUR STRONG PARTNER

Quality made in Germany, creativity and the utmost commitment to customers and business partners: these form the basis on which KUKA develops the best possible technologies and thus the optimal automation concepts. The result is that you receive custom-tailored solutions and benefit from decisive process optimization.

Genuine passion for the fascination of robotics is reflected in our slogan “KUKA YOUR IDEAS”, which is also our promise to you: Whatever you want to do, and however unusual your idea may be, with us you can implement anything – irrespective of the specific branch of industry and irrespective of whether or not a similar application has existed before.

Whatever task you give us, KUKA has the required specialists. In close cooperation with experienced system partners with competence in their respective industries, we do everything in our power to implement your ideas. Let us work on them together.

»KUKA SERVICES: ALWAYS THERE FOR YOU

You can rely on us to stand by you in every phase of a project: from planning and commissioning to maintenance and conversion. 24 hours a day. 365 days a year. The high-density KUKA service network ensures that we are always in your vicinity and can start your production in record time.

KUKA YOUR IDEAS

KUKA ROBOTER GMBH

Global Sales Center
Hery-Park 3000
86368 Gersthofen
Germany
Tel. +49 821 4533-0
Fax +49 821 4533-1616
info@kuka-roboter.de

Additional contact addresses:
www.kuka-robotics.com