



KR 3 R540



Technical data

Maximum reach	541 mm
Maximum payload	3 kg
Pose repeatability (ISO 9283)	± 0.02 mm
Number of axes	6
Mounting position	Floor; Ceiling; Wall
Footprint	179 mm x 179 mm
Weight	approx. 26.5 kg

Axis data

Motion range	
A1	±170 °
A2	-170 ° / 50 °
A3	-110 ° / 155 °
A4	±175 °
A5	±120 °
A6	±350 °

Operating conditions

Ambient temperature during operation	5 °C to 45 °C (278 K to 318 K)
--------------------------------------	--------------------------------

Protection rating

Protection rating (IEC 60529)	IP40
Protection rating, robot wrist (IEC 60529)	IP40

Controller

Controller	KR C5 micro; KR C4 compact
------------	-------------------------------

Cycle time

167 cycles per minute (25 mm / 305 mm / 25 mm, 1 kg)



Workspace graphic

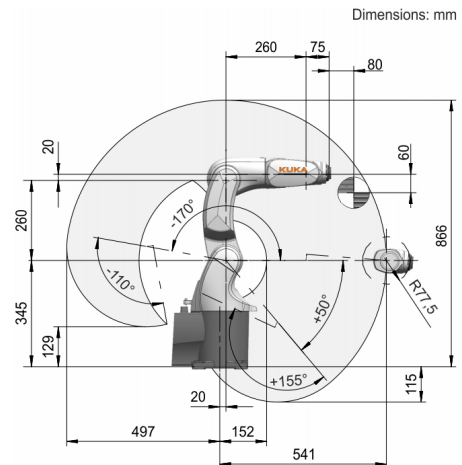

Payload diagram

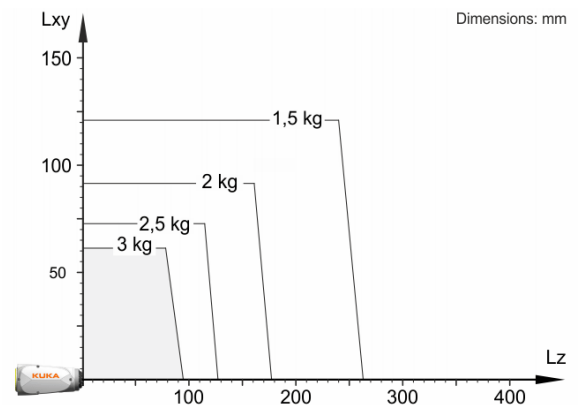

The KR 3 R540 is designed for a rated payload of 2 kg in order to optimize the dynamic performance of the robot. With reduced load center distances and favorable supplementary loads, a maximum payload of up to 3 kg can be mounted. The specific KUKA Load case must be verified using KUKA. For further consultation, please contact KUKA Service.

Mounting flange

